

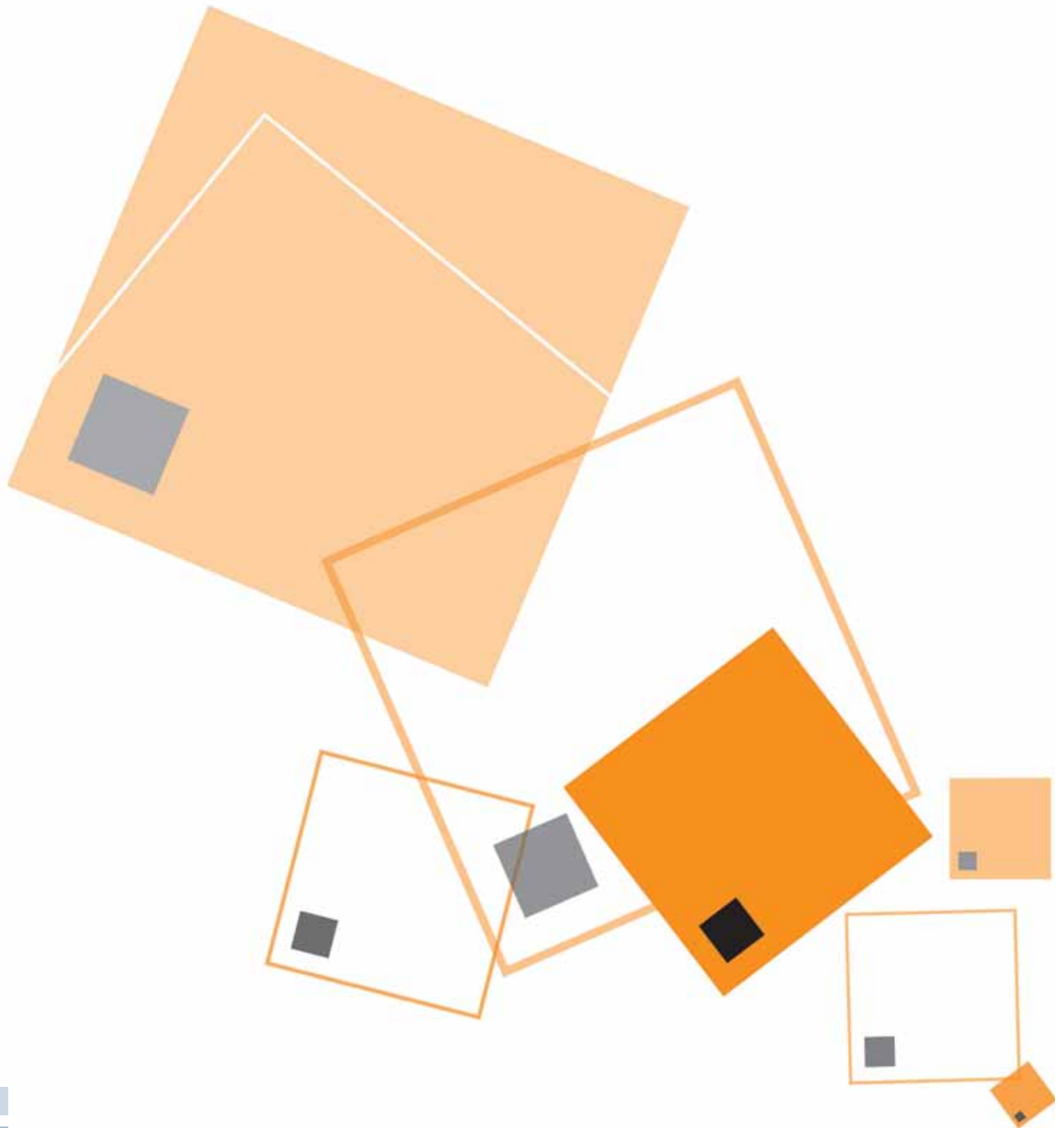

c.p. bourg®

The Print Finishing Experts



ON-LINE PRODUCTS

C.P. BOURG: THE COMPANY



Modern assembly lines



State of the art machine tools

The Three Cornerstones of C.P. Bourg: Quality, Innovation and Efficiency

QUALITY

Our employees work constantly to strengthen our industry leadership position and to achieve the common goal of total customer satisfaction. Quality is the result of our continuous care to apply efficient controls to each step of the development and manufacturing process. C.P. Bourg is known worldwide as a name for quality, leading to privileged relationships with companies such as Kodak, HP, Océ, Xerox, Ricoh and more.

The C.P. Bourg Quality System is ISO 9001 certified.

INNOVATION

At C.P. Bourg, innovation is a primary objective. To this end, we make a continuous effort to develop and improve products corresponding to the needs of our customers. Steady feedback from our global customer base provides the guidance for our innovative ideas.

C.P. Bourg innovation has been recognized in the past by multiple industry awards, like the prestigious GATF Intertech Excellence granted to the BB2005 on line binder.

EFFICIENCY

Our efficiency results from investment in our people and facilities. Such investment enables the integration of the latest technologies into our manufacturing process, as well as the development of high-performance products that are both dependable and competitive.

At C.P. Bourg, we develop and manufacture “on demand” print-finishing products in conjunction with world leaders in the digital-printing industry who have their own worldwide distribution networks.

C.P. Bourg operates three manufacturing sites, two in Belgium and one in the United States. Our products are distributed in Europe via our Belgian headquarters, subsidiaries in Belgium, Luxembourg, France and Germany, and via dealers. Throughout North and South America, Bourg products are distributed by C.P. Bourg Inc., headquartered in New Bedford, Massachusetts. In all other markets, we have a network of independent distributors providing both sales of and service for our products.

More than sixty thousand customers can testify to our continuous commitment to building products of quality, innovation, and efficiency for the future.

EURO-QUALITY SYSTEM



DIGITAL ON-LINE PRODUCTS

— On-line program for digital printer equipment users	4
— Bourg Book Factory for Xerox Nuvera Docutech BW and HLC	5
— Bourg Book Factory for Xerox iGen3	6
— Bourg Binder BBF2005	7
— CMT 330 Three-Knife Trimmer	8
— Bourg Perforating Rotating and Folding BPRFx	9
— Bourg Sheet Rotator BSR	10
— Bourg Cover Feeder BCFx	11
— Bourg Bleed-Crease Module BCMx	12
— Bourg Booklet-Maker BDFx	13
— Square Edge Accessory	14
— High Capacity Stackers	15
— Kodak on-line products	16
— Océ on-line products	17

ON-LINE PROGRAM FOR DIGITAL PRINTER EQUIPEMENT USERS

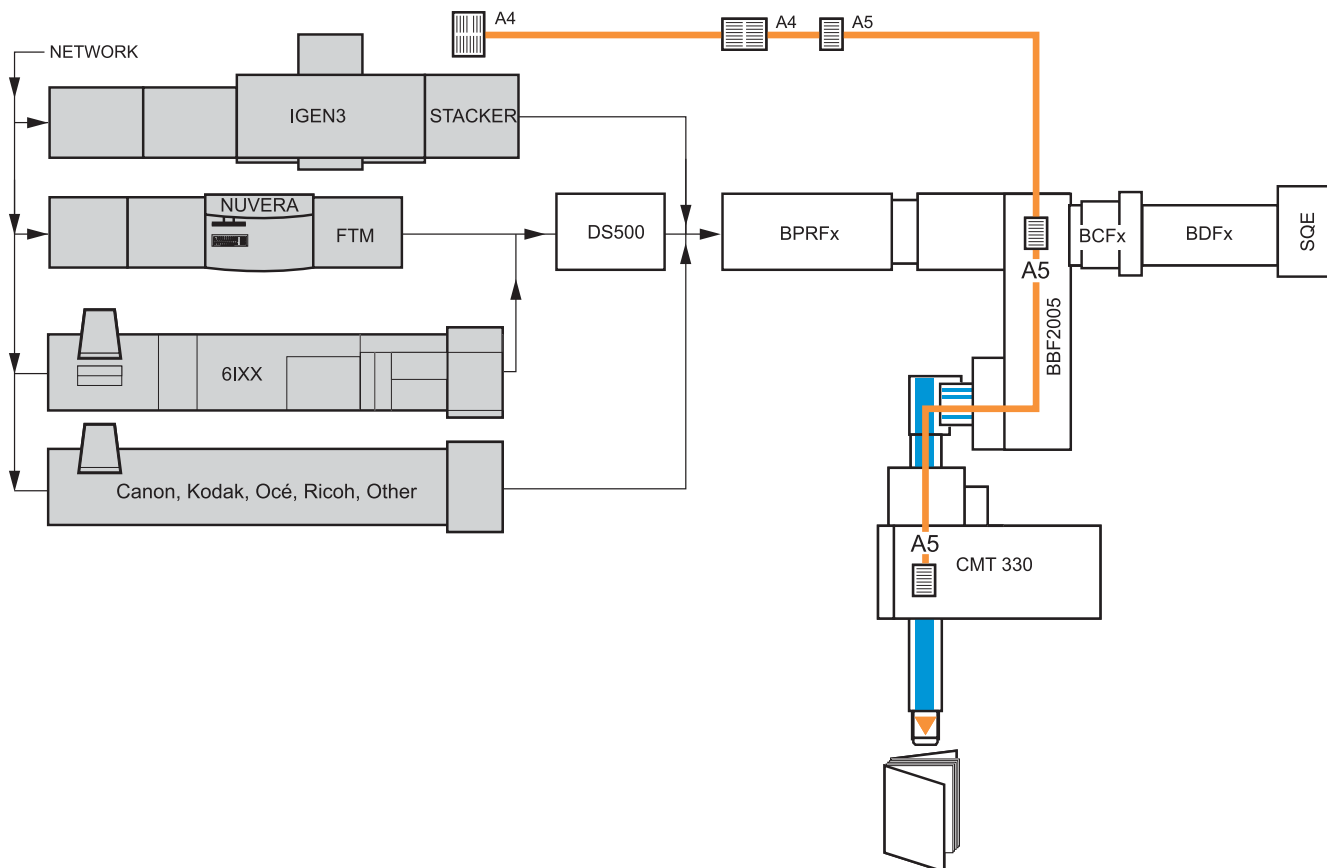

■ DS 5000 HIGH CAPACITY STACKER (DOCUTECH AND NUVERA)

DS 5000 provides uninterrupted operation for long-run productivity. Each unit stacks up to 5.000 sheets in a wide range of paper sizes. Ganged stackers configuration possible.

■ BPRFx BOURG PERFORATING ROTATING FOLDING UNIT

BPRFx transforms sheets into signatures by a process of perforation, rotation and folding.

■ BBF2005 BOURG BINDER

BBF2005 is fully synchronised mechanically and electronically with the Digital Printer to produce bound documents from 15 sheets to 40mm (1.6") thickness.

■ CMT 330 THREE-KNIFE TRIMMER

Automatic perfect cuts.

■ BCMx BLEED CREASE MODULE

Bleed and crease your production on the fly.

■ BCFx BOURG COVER FEEDER

BCFx automatically inserts covers on the top of each set.

■ BDFx BOURG DOCUMENT FINISHER

BDFx is a fully automated high end booklet maker combining 3 functions in one self-contained unit: stitch, fold, trim.

■ SQE SQUARE EDGE

Connects to new or existing BDFx to enhance saddle stitched booklets and give them the look of perfect bound booklets.

BOURG BOOK FACTORY FOR XEROX NUVERA AND DOCUTECH B+W AND HLC (AND OTHER HIGH-END PRINTERS)



The Bourg Book Factory enables you to produce finished booklets with ease, speed and flexibility as never offered on-line before.

The digital Bourg Book Factory is a totally automated in-line booklet finishing system.

The Bourg Book Factory utilizes combined technologies of Xerox Corporation and C.P. Bourg.

The sheets are fed in-line into a Xerox Printer which prints black and white digital images. The printed sheets from the Xerox Printer are fed into a choice of C.P. Bourg finishing devices.

The Finishing line can start with a **DS 5000** (High Capacity Stacker) to stack up to 5000 sheets in straight or offset stacks. More stackers can be added to enable unload on the run operation.

Sheets can go through the by-pass of the **DS5000** into the **Bourg BPRFx** where they are transformed into signatures - by a process of perforation, rotation and folding.

Double the pages per click charge. They are then transferred to the **Bourg BBF2005** binder that binds these signatures into final perfect bound booklets which are finally three-side trimmed in the on-line three-knife trimmer for immediate delivery. The **BPRFx** can be by-passed to feed single sheets to **BBF2005** binder. For applications requiring commercial quality saddle-stitched documents, sheets can be sent through the by-pass of the **BBF2005** binder to go in-line directly to the **BDFx** Bourg Document Finisher, optionally upgraded with a **BCFx** Cover Feeder and/or a **SQE** (Square Edge module).

The Bourg Book Factory allows you to produce finished booklets easier, faster and more flexibly than ever before. Variants of Bourg Book Factory are available for many makes of high-end printers.

ADVANTAGES:

- Full job integrity.
- Full job recovery.
- Less manpower.
- Less waste.
- Immediate set up.

OPTIONS:

BCR Integrity check available through third parties.

BOURG BOOK FACTORY FOR XEROX IGEN3

(ALSO FOR **DOCUCOLOR** 7000/8000)



The Bourg Book Factory that is well known in the Digital Black and White printing world is available for the high end color digital printing as well. It combines ease of use, speed and flexibility matching the high quality of the color printing on the Xerox iGen 3 or Docucolor.

The digital Bourg Book Factory is a totally automated in-line booklet finishing system.

The digitally color printed sheets are fed in-line from Xerox iGen3 to the Xerox High Capacity Stacker and DFA Interface. They then transfer to the C.P. Bourg finishing devices.

The first device can be a **Bourg BPRFx** that converts printed sheets in single fold signatures, by processing the sheets in a no stop perforation - rotation and folding operation. These

signatures are then transferred to the **Bourg BBF2005** binder which binds them into final perfect bound booklets which are finally three-side trimmed in the on-line three-knife trimmer for immediate delivery. The **BPRFx** can be by-passed in case you want to run single sheets to the **BBF2005 BINDER**.

For applications requiring commercial quality saddle-stitched documents, single sheets can be sent via a by-pass on the **BBF2005** binder directly to the **BDFX** - Bourg Document Finisher. Optionally upgraded with a **BCFX** Cover Feeder and/or a **SQE** (Square Edge module).

The Bourg Book Factory for Xerox iGen3 is a unique book finishing device that allows you to produce finished booklets easier, faster and on a much more flexible way than ever before.

ADVANTAGES:

- Full job integrity.
- Full job recovery.
- Less manpower.
- Less waste.
- Immediate set up.

OPTIONS:

BCR Integrity check available through third parties.

BOURG BINDER **BBF2005**



Publish documents on-demand with industry leading digital printers, Xerox, Océ, Kodak, Canon, Ricoh and others.

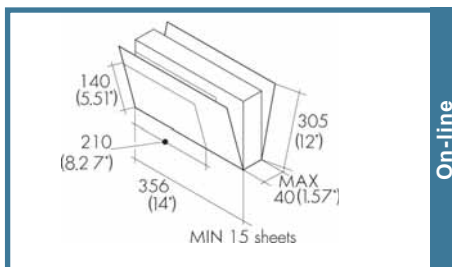

On-line

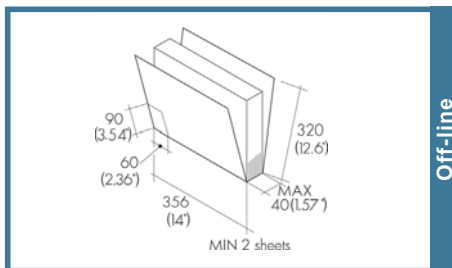

Off-line

All dimensions in mm (inches)

Today's technology makes on-demand document production a reality. With one operator, this integrated on-line system can produce quality commercial bound documents in your facility.

The Bourg Binder **BBF2005** is synchronised technically and electronically with the printer's output. Automatically adjusted to the printing system's speed, the **BBF2005** can be connected to most industry leading digital printers.

In addition, the C.P. Bourg by-pass system allows you to combine the **BBF2005** with the Bourg Document Finisher BDFx. With this full configuration, at the turn of a switch, the desired finishing method can be chosen: either perfect bound booklets or saddle stitched documents.

ADVANTAGES:

- Compatibility: DT1xx, DT61xx, DP1xx, DP92, DP 180 HLC, 41xx, 46xx, Nuvera 120/144/ 288, iGen3,... (may require specific interface kit). Océ, Kodak, Canon, Ricoh top end products.
- Product validated by Xerox and other printer manufacturers.
- Memory for recording the parameters of 4 binding jobs.
- Milling and/or notching of the spine for better adherence.
- Binds from 15 sheets to 40 mm (1.57").
- Can be used off-line.

CMT 330 THREE-KNIFE TRIMMER



On-line trimming of your books.

The **CMT 330** three-knife trimmer finishes soft-cover, perfect bound books at a rate of up to 400 books per hour. Designed for on-demand digital printing, it can also find its place in a traditional offset printing workshop. Fully automatic, the **CMT 330** nevertheless lets you control the entire production process.

It is also possible to connect the **CMT 330** on-line with the **BB 3002**.

Used in-line, perfectly integrated in the finishing line of a digital on-demand printing system, the **CMT 330** will ensure the finish of the perfect bound books produced by the **BBF 2005**, in all production configurations with Xerox, Océ, Kodak, Canon, Ricoh, ... digital printers.

ADVANTAGES:

- Full digital control for fast, accurate changeovers.
- Production rate up to 400 books per hour.
- Toolless changeovers.
- Easy to use and program.
- Graphic LCD user interface.
- Hydraulic cutting.
- Eight-station cooling tower for on-line systems.
- Serial communication enables remote setup for automated bookshop environments.
- Enables book size changes without productivity loss.
- Can be used off-line.

BOURG PERFORATING ROTATING FOLDING UNIT **BPRFx**



The only answer for editing on demand with click cost reduction.

The Bourg **BPRFx** enables our on-line Binder to produce high quality low waste documents with minimal operator intervention. Simple to operate, an A4 size sheet exits the printer and enters the **BPRFx** unit. This sheet of paper is immediately perforated with a micro perf across its center. The sheet is then turned 90° and folded on the perforation. This printed, perforated and folded sheet of

paper exits the **BPRFx** and enters the accumulating section of the Bourg Binder **BBF2005**. All of the sheets of the job are gathered in this section until the whole job has been completed. The **BBF2005** then jogs the sheets together, mills the folded edge of the sheets, applies adhesive, wraps a cover around them and delivers you a ready to be trimmed A5 size bound book.

ADVANTAGES:

- Full job integrity.
- Full job recovery.
- Less manpower.
- Less waste.
- Immediate set up.

OPTIONS:

BCR Integrity check available through third parties.

BOURG SHEET ROTATOR BSR



Rotating the sheets to avoid productivity losses when going to in line booklet maker (increases productivity by up to 25%).

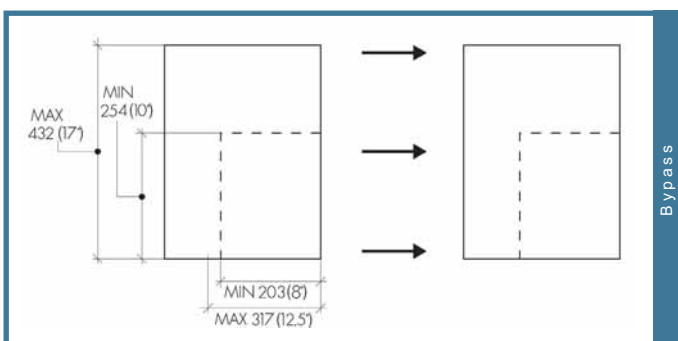
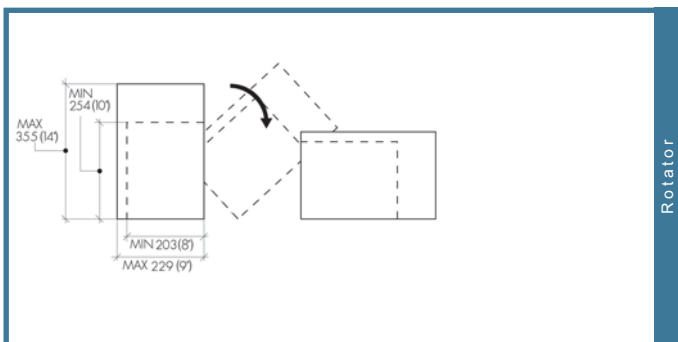

All dimensions in mm (inches)

The **BSR** handles the output from Xerox DP printers, black and white, high light color and iGen3 full color printers.

It rotates sheets as needed to enable saddle stitching and other booklet making applications on printers that do not have rotator function built in.

ADVANTAGES

- Compatibility : DP1xx, 41xx, 46xx, DP 180 HLC, iGen3, Nuvera 120, 144, 288,...
- Manual rotate / don't rotate selection.
- Product validated by Xerox and Ricoh.

BOURG COVER FEEDER BCFx



Give a professional touch to your booklets by using separately printed covers.

The **BCFx** is a cover feeder module that can increase your versatility by offering more automation to your high volume digital printer or copier.

With the **BCFx**, you can personalize your booklets with a preprinted cover without decreasing the loading capacity of the Printer/Copier.

It also enables higher productivity than if cover is fed by the printer.

If you want to add a cover to your booklets, simply load the **BCFx**, adjust it (it takes only a moment) and switch it on: the covers will be automatically inserted on the top of each set before the booklet is stitched, folded and trimmed.

The result: a professionally finished booklet.

ADVANTAGES:

- Compatibility : DT1xx, DT61xx, DP1xx, DP92, 41xx, 46xx, Nuvera 120, 144, 288, ... (may require specific interface kit).
- Product validated by Xerox.
- Product designed to meet DP 180 HLC requirements.
- Suction feed mechanism.
- Installed quickly without requiring any special tools.

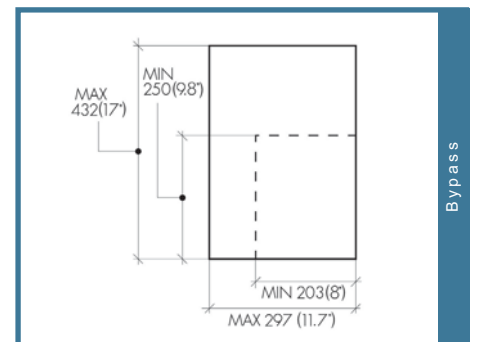

Bypass

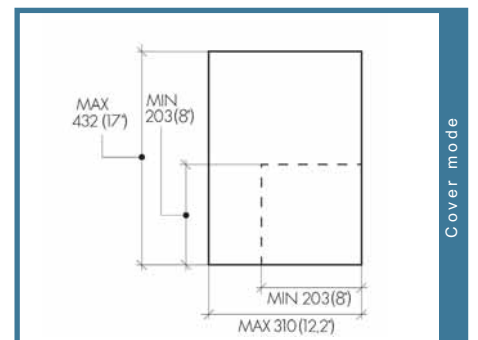

Cover mode

All dimensions in mm (inches)

BOURG BLEED-CREASE MODULE BCMx



The **BCMx** is the only on line bleeder creaser able to process jobs at the full speed of the iGen (no skip pitch needed as on other makers devices) you run at full production all the time! Booklets with bleed now look as if they were 3 knife trimmed straight from your printer!

ADVANTAGES:

- Can take full sized iGen sheets. Entering size up to 364 mm x 578mm short end first (larger than any other device) min 178 mm x 178 mm.
- The BCMx works on a margin and thus the slitting positioning is more precise and it allows for offset slitting (in the case of non-centered image drift for example).
- Biggest waste collection bin, you can run for min. 4 hrs before unloading. Unloading on the run is possible.
- Unique creasing roller technology, this is the part that creases as the sheet travels through the machine, so the sheet never has to stop (unlike other makers machines) so you have full production all of the time.
- Bypass function if no bleed trimming needed, creasing operational in this mode as needed.
- Fits directly (no conveyor or adapter needed) to most Xerox production printers.
- Validated by Xerox for iGen3 printer.

BOURG DOCUMENT FINISHER BDFx



Fast and flexible, it can be linked to virtually any digital printer.

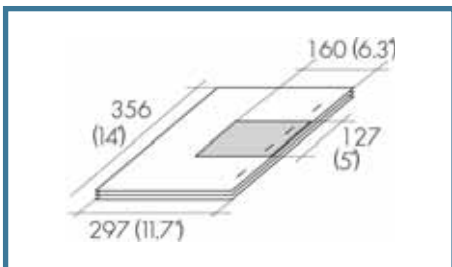
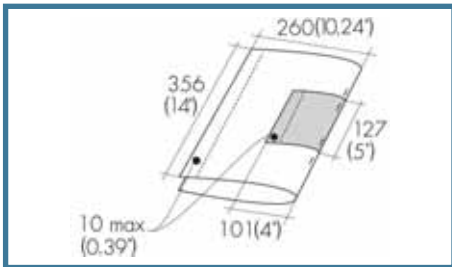

All dimensions in mm (inches)

The Bourg document Finisher is a **purpose designed** fully automated signature booklet maker. The **BDFx** requires absolutely no tools for changeover in sheet size or application. It is key-pad controlled. The **BDFx** also has complete paper path sensing system ensuring that document production is monitored throughout each step of the process. The **BDFx** is capable of top or corner stitching, from 2 sheets to 55 sheets of 80 gsm (22 sheets if folded); and can produce saddle stitched documents of up to 88 pages in thickness at an amazing production rate when combined with a Xerox 288 ppm printer. The **BDFx** can accommodate both coated and uncoated stock with ease.

The Bourg Document Finisher truly enables “push button” document production for stitching or signature document applications.

ADVANTAGES:

- Compatibility : DT1xx, DT61xx, DP1xx, DP92, DP180 HLC, 41xx, 46xx, Nuvera 120, 144, 288, iGen3,... (may require specific interface kit).
- Product validated by Xerox and Ricoh.
- Stitching heads equipped with unique self threading stitching wire cassette (toolless cassette change).
- **BDFx** is available on-line in configurations with other printer manufacturers.

SQUARE EDGE ACCESSORY



Square edge professional finish, saddle-stitching accuracy.

The ideal complement of a **BDFx**, the Square Edge Accessory **SQE** takes traditional stitch-fold -trim booklets and transforms them, into Square Edge booklets that are flat and easy to pack, stack and handle. You can even print on the spine. These booklets have the

professional flat appearance of perfect bound books. As soon as it exits the **BDFx**, the stitch-fold trim booklet is sent into the Square Edge Accessory and its spine is re-formed into a square shape enabling an easy and clean stacking of the booklets.

ADVANTAGES:

- Removable module controlled by the BDFx.
- Can be physically disconnected to allow reception of saddled-stitched booklets on the BDFx exit conveyor.
- The spine pressing function can be bypassed.
- Adjustable pressure.
- Overall bulk is reduced by over 30%.
- Superior quality and appearance means added value.

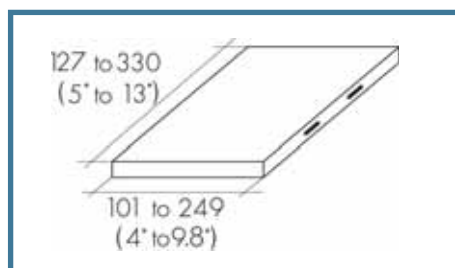

All dimensions in mm(inches)

HIGH CAPACITY STACKERS FOR XEROX



Docutech high capacity stacker DS5000

ADVANTAGES:

- For all DT1xx, DT61xx, Nuvera 120/144 and 288.
- Max Capacity: 500 mm (19.7") (5000 sheets 80 gsm).
- Media size range 178 mm x 254 mm to 470 mm x 364 mm (7" x 10" to 18.5" x 14.33").
- Multiple units can be connected together for unload while run operation.
- Overall bulk is reduced by over 30%.
- DS5000 Output: BBF 2005 / BDFx (and many other DFA devices).

DIGITAL ON-LINE FOR KODAK



Books On-Demand with Kodak Digimaster EX Platform

HIGH CAPACITY STACKER

Up to 3 stackers, each capable of stacking up to 5000 sheets (80 gsm) can be connected in-line with printer. Paper is received on roll away cart for convenient transport of stacks for off-line finishing device.

Optional carts available on request. Features rotating capability and by pass to booklet maker or binder.

Manufactured by C.P. Bourg and supported by Kodak, Canon, Ikon, Infotech (Ricoh) and Danka (Konica Minolta).

PERFECT BINDER

The Perfect Binder produces cover-bound books to a maximum thickness of 40 mm (1.5") (about 350 sheets of 80 gsm). It accepts a variety of cover types including one side, gloss-coated paper and cutout or transparent front covers.

The versatility of the Perfect Binder is increased with milling and scoring capabilities plus paper waste collection. Manufactured by C.P. Bourg and supported by Kodak, Canon, Ikon, Infotech (Ricoh) and Danka (Konica Minolta).

BOOKLET MAKER

A professional finish every time fully-integrated Booklet Maker delivers folder pamphlets from 15 different-sized sheets, including 8.5" x 11", 11" x 17" and A4. Automatically assembles and collates to deliver finished pieces using different paper types – from cover stock to stock of varying grain and thickness. Manufactured by C.P. Bourg and supported by Kodak, Canon, Ikon, Infotech (Ricoh) and Danka (Konica Minolta).



DIGITAL ON-LINE FOR OCÉ



Books On-Demand with Océ.

PROFESSIONAL LOOKING, PERFECT BINDING

The SDD BGB1208 binder handles books and documents of varying thickness and media types. Publishing on demand means exactly that you can print complete books whenever you need them, and you can bind them to professional standards with the SDD BGB1208 binder. With a binding capacity of up to 350 sheets, this binder can easily and automatically handle even the largest print runs. It produces a very strong bind by rapid cooling of the glue in conjunction with milling of his spine.

The binder is technically and electronically synchronized, with the printers output and automatically adjusts to the printer's speed. All in all, the SDD BGB1208 is quick to set up and very simple to operate.

FULL INTEGRATION WITH OCÉ

The SDD BGB1208 binder can be seamlessly integrated with various Océ printers while maintaining full printer operating speed. Operating online with an Océ printer, collates the prints, binds the finished documents using glue, and delivers them nearly stacked. The printer and the SDD BGB1208 are linked together for perfect communication. The physical integration of printer and binder ensures a smooth, trouble-free process, reducing manual intervention to an absolute minimum.

OFFLINE OPERATION

The SDD BGB1208 binder can also be used offline if required. In this mode, print sets from different printers are fed into the SDD BGB1208 binder using the offline document input.

OPTIONS

The SDD PRF1000 (perforate, rotate and fold) unit required for A4 sheets into A5 signatures prior to binding.

The Challenge CMT 330 3-knife trimmer is designed to trim all 3 sides of the book. Just key in the starting and finished sizes and the trimmer automatically does the rest.

C.P. BOURG COMPANIES

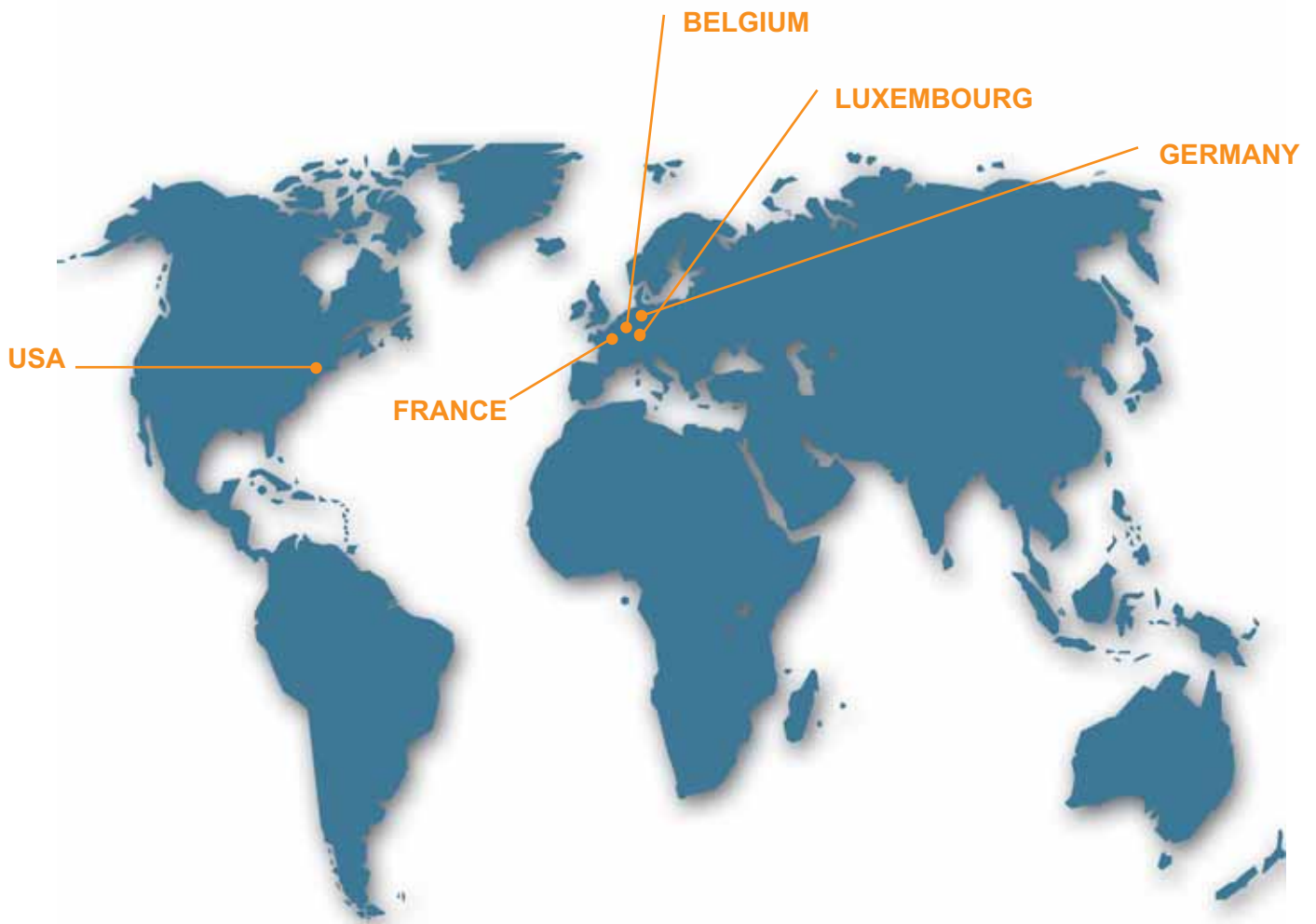

C.P. BOURG COMPANIES ARE COMMITTED TO BE THE WORLD LEADER IN THE DEVELOPMENT, MANUFACTURE AND SUPPORT OF POST PRINTING SOLUTIONS. WE MEET OUR OBJECTIVES THROUGH TOTAL CUSTOMER SATISFACTION. OUR WORLDWIDE TEAM OF EMPLOYEES IS DEDICATED TO MEETING THE NEEDS OF OUR CUSTOMERS THROUGH A COMMITMENT OF CONTINUOUS QUALITY LEADERSHIP.

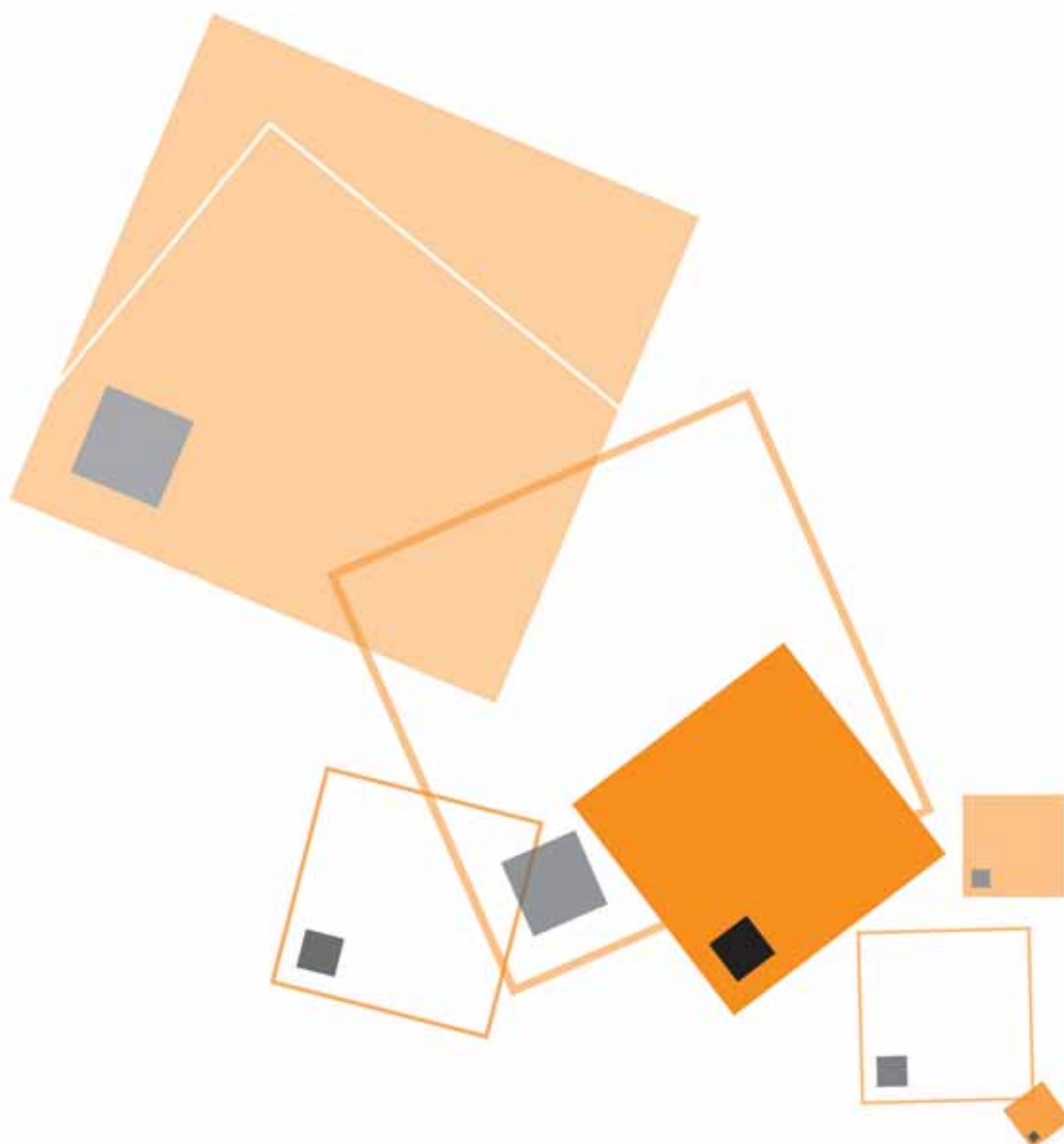

BELGIUM

C.P. Bourg S.A. N.V.
Group European Headquarters
22, rue des Technologies
B-1340 Ottignies
Belgium
Tel.: +32 10 62 22 11
Fax: +32 10 61 36 38
Export fax: +32 10 61 63 55
E-mail: contactus@cpbourg.com
export.be@cpbourg.com

FRANCE

C.P. Bourg S.A.
Parc d'Affaires Silic
32, rue des Gémeaux
BP 60410
F-94573 Rungis
France
Tel.: +33 1 46 87 32 14
Fax: +33 1 46 87 52 17
E-mail: cpbourg_france@cpbourg.com

USA

C.P. Bourg Inc
USA Headquarters
50 Samuel Barnet Blvd.
New Bedford, MA 02745
USA
Tel.: +1 508 998 2171
Fax: +1 508 998 2391
E-mail: cpbourgusa@cpbourg.com

GERMANY

C.P. Bourg GmbH
Schweizerstrasse 70/1
D-72336 Balingen
Germany
Tel.: +49 7433 9981 680
Fax: +49 7433 9981 686
E-mail: cpbourg_germany@cpbourg.com

LUXEMBOURG

Ets C.P. Bourg Luxembourg S.A.
14 rue Millewee, B.P. 85
L-7201 Walferdange
Luxembourg
Tel.: +352 33 24 47
Fax: +352 33 19 99
E-mail: cpbourgluxembourg@cpbourg.com